



90 Series Brake Instructions

Read carefully before attempting to assemble, install, operate or maintain the product described. Protect yourself and others by observing all safety information. Failure to comply with instructions could result in personal injury and/or property damage! Retain instructions for future reference. When unpacking the brake, inspect it carefully for damage that may have occurred during transit.

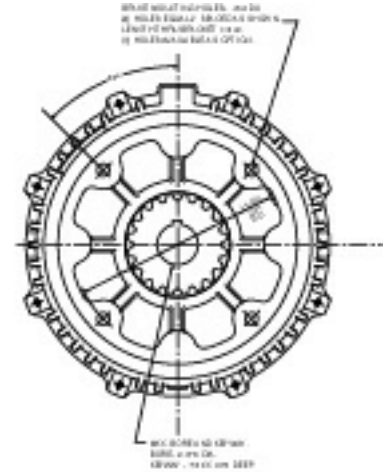
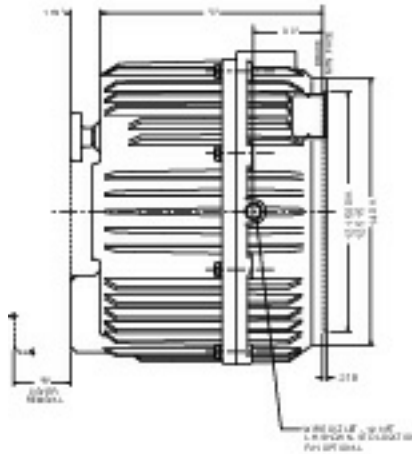

Figure 1.

MODEL NO.			TORQUE LB. FT.	C	R	AC	INERTIA WK ² LB. FT. ²	WEIGHT LBS.
STD. HSG.	ENCL. HSG.	SEVERE DUTY HSG.						
2-92180-30	4-92180-31	6-92180-32	180	10 3/8	6 3/4	2.53	1.00	195
2-93270-30	4-93270-31	6-93270-32	270	10 3/8	7 1/2	2.53	1.38	205
2-94360-30	4-94360-31	6-94360-32	360	11 1/2	7 1/8	3.65	1.84	240
2-95450-30	4-95450-31	6-95450-32	450	11 1/2	7 7/8	3.65	2.30	250

WARNING

Brake performance and features must be carefully matched to the requirements of the application.

Consideration must be given to torque requirements, especially where an overhauling condition exists, as well as thermal capacity, ambient temperature, atmospheric explosion hazards, type of enclosure and any other unusual conditions.

Improper selection and installation of a brake and/or lack of maintenance may cause brake failure which could result in damage to property and/or injury to personnel.

If injury to personnel could be caused by brake failure, additional means must be provided to insure safety of personnel.

BRAKE OPERATION

Refer to Figure 3.

During brake setting, rotating discs (5), stationary discs (6), and the pressure plate (7) are forced against the bracket (1) by the torque springs (53) and (54), transmitted through the shock absorbers (46). The friction developed between the discs is transmitted through the rotating discs and hub (3) to the motor shaft as torque. When the magnet coils are energized, the magnetic field generated attracts the pressure plate; the rotating discs, hub and shaft are then free to turn. As the friction discs wear, the magnet gap will increase. The magnet gap should be checked periodically and adjusted when necessary.

DESCRIPTION

The 90 Series Brake is a spring set, electro magnetically released unit. Heavy duty friction discs are standard and consist of non-asbestos friction material bonded to an aluminum carrier. An automatic reset manual release is standard (deadman release optional).

SPECIFICATIONS

MOTOR FRAMES - 324TC, 326TC, 364TC, 365TC, 404TC, 405TC
HOUSINGS - Cast iron.

DUTY - Rated for continuous duty.

VOLTAGES - All standard NEMA voltages and frequencies available. Other voltages and frequencies are optional.

MOUNTING - Direct to NEMA "C" motor flanges. Adaptors for larger or smaller frames, foot mounting and vertical mounting are available.

MANUAL RELEASE OPERATION

Refer to Figure 3.

1. **AUTOMATIC** — Turning the release knob (9) clockwise until it stops, will release the brake. It will remain in the released position until the knob is manually returned to its original position, or until magnet coils are energized which automatically returns the knob to its original position. NOTE: Due to the size of the discs, a slight drag is common (5-7 lb. ft.).

2. **DEADMAN** — Turning the release knob (9) clockwise until it stops, will release the brake. Knob will immediately return to its original position when the turning force is removed. NOTE: Due to the size of the discs, a slight drag is common (5-7 lb. ft.).

INSTALLATION

(Refer to Figures 2, 3, 4 & 5)

1. STANDARD HOUSING — Install hub (3) onto motor shaft with key per dimension "N" as shown in Figure 3. Hub part number should face away from motor. Tight hub set screws with 20 ft. lb. of torque.
2. ENCLOSED HOUSING — Slide seal ring (61) onto motor shaft as shown in Figure 3. Install hub (3) onto motor shaft with key per dimension "N" as shown in Figure 3. Hub part number should face away from motor. Butt seal ring (61) against hub, and tighten set screws in both hub and seal ring with 20 ft. lbs. of torque. Apply a small amount of grease to O.D. of seal ring. **CAUTION: Excessive grease could work its way onto the rotating disc causing loss of torque.**
3. DISASSEMBLY — Disassemble brake by removing cover screws (14), lockwashers (13), cover (8), locknuts (16), operator assembly (60), jam nuts (15), pressure plate (17), rotating discs (5), and stationary discs (6).
4. REASSEMBLY — Mount bracket (1) (with mounting gasket (59) when used) onto motor using 5/8-11 hex socket head screws. Be sure wire outlet location is correct. Install rotating discs (5), stationary discs (6), and pressure plate assembly (7) in the order shown in Figure 3. NOTE: All numbers and letters to be facing towards you during assembly. The stamped "O" on the hub tooth should line up with the stamped number on the tooth space of the rotating disc. The stamped number on the stationary discs and stamped letter "P" on the pressure plate should be towards the top of the brake. (See Figure 5.) Install jam nuts (15) approximately 1 1/2" from end of studs (2). Washer face on jam nuts to face towards you. Place operator assembly (60), with release shaft at top, onto brake over the studs. Install locknuts (16) on end of studs only. Block operator arm (35) to insure proper air gap setting. (See Figure 4.) To block operator arm: push at point "X", then place an object between the operator arm and the magnet plate. Be sure not to place the object against the manual release. Push the operator assembly forward until it is flush with the pressure plate at the

magnet faces. If the operator arm is properly blocked the magnet faces will be flush and the two shock absorbers (46) will be free to move back and forth. Again push operator assembly towards motor to take up all clearances.

5. MAGNET ADJUSTMENT — Adjust air gap "A" between locknuts and magnet plate face using a spacer equal to air gap "A" nominal per appropriate model, refer to Figure 3. Then pull the magnet plate back against all eight locknuts (16). Bring the jam nuts (15) back to magnet plate and tighten evenly. Remove object blocking operator arm. Check air gap after removing block. Readjust if necessary. Connect lead wires per wiring diagram as shown in Figure 2. Apply rated voltage to brake. If there is a loud magnet noise, find the area of heavy vibration by placing a finger on each end of the four magnets in the area where it meets the pressure plate. Using nuts (15) and (16), on the stud (2) closest to the vibration, move magnet plate in and out, by loosening one nut and tightening the other, 1.8 turn maximum. Adjust in and out until magnet noise is reduced. Continue this process around all eight studs if needed, until magnet noise is at a minimum.

6. COVER INSTALLATION — Install cover (8) (with gasket (58) when used) making sure pin in release handle (9) is facing up for proper alignment with release shaft, add cover screws (14) with lockwashers (13).

TORQUE ADJUSTMENT

(Refer to Figure 3.)

Torque springs (53) and (54) are installed at the factory per dimension shown, 1 1/6". (See Figure 3.) This setting will give the rated torque for all models. To reduce torque (which will increase stopping time), increase installed setting. The maximum setting is 1 7/16". This will reduce torque by 20%. To do this, first loosen locknut (16), then bring the torque adjusting screw (41) out to the desired length. Then while holding the adjusting screw in place, tighten locknut (16). **IMPORTANT:** Do not decrease spring length, as this may cause coils to burn out.

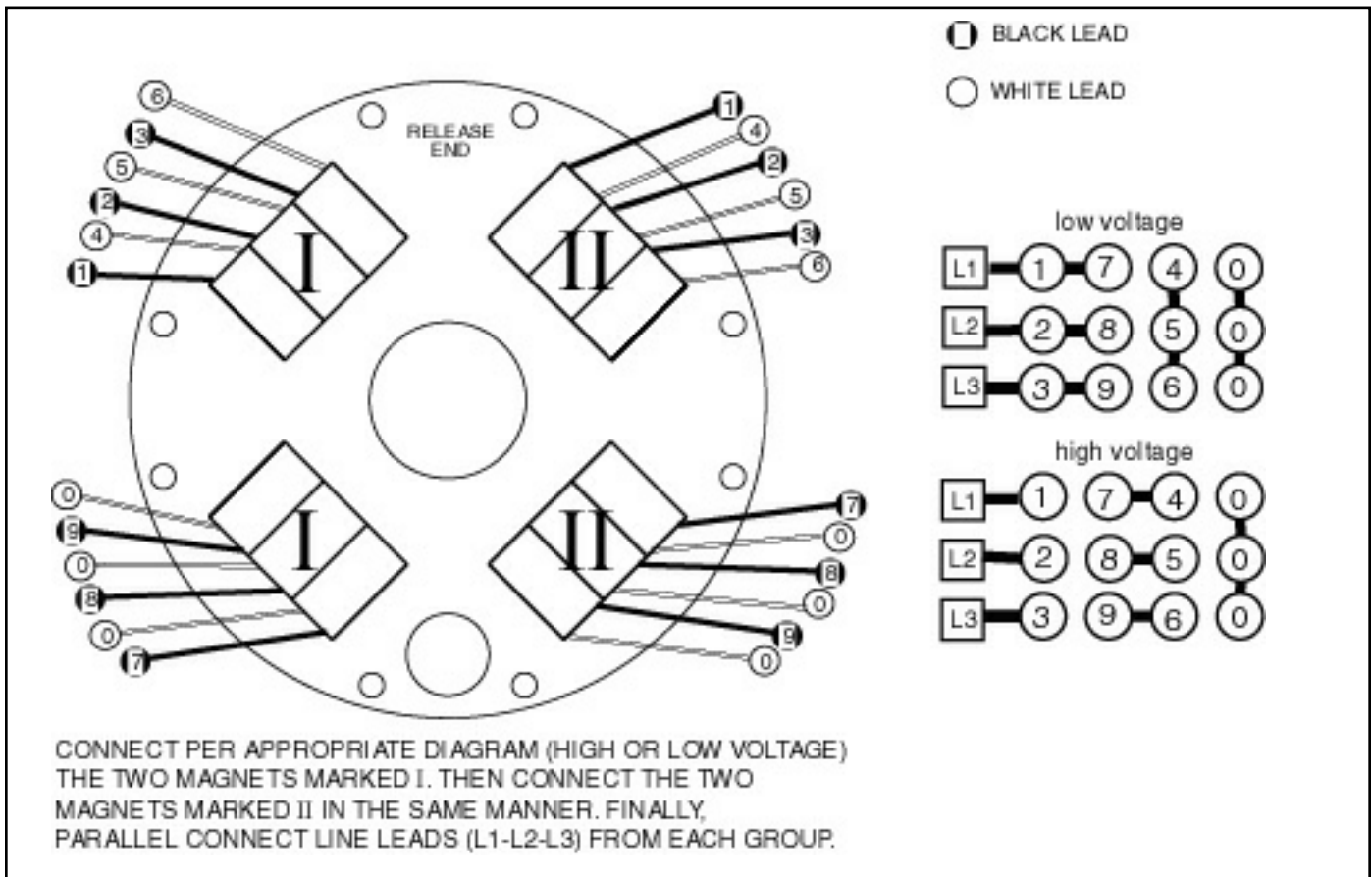

Figure 2. Wiring Diagram

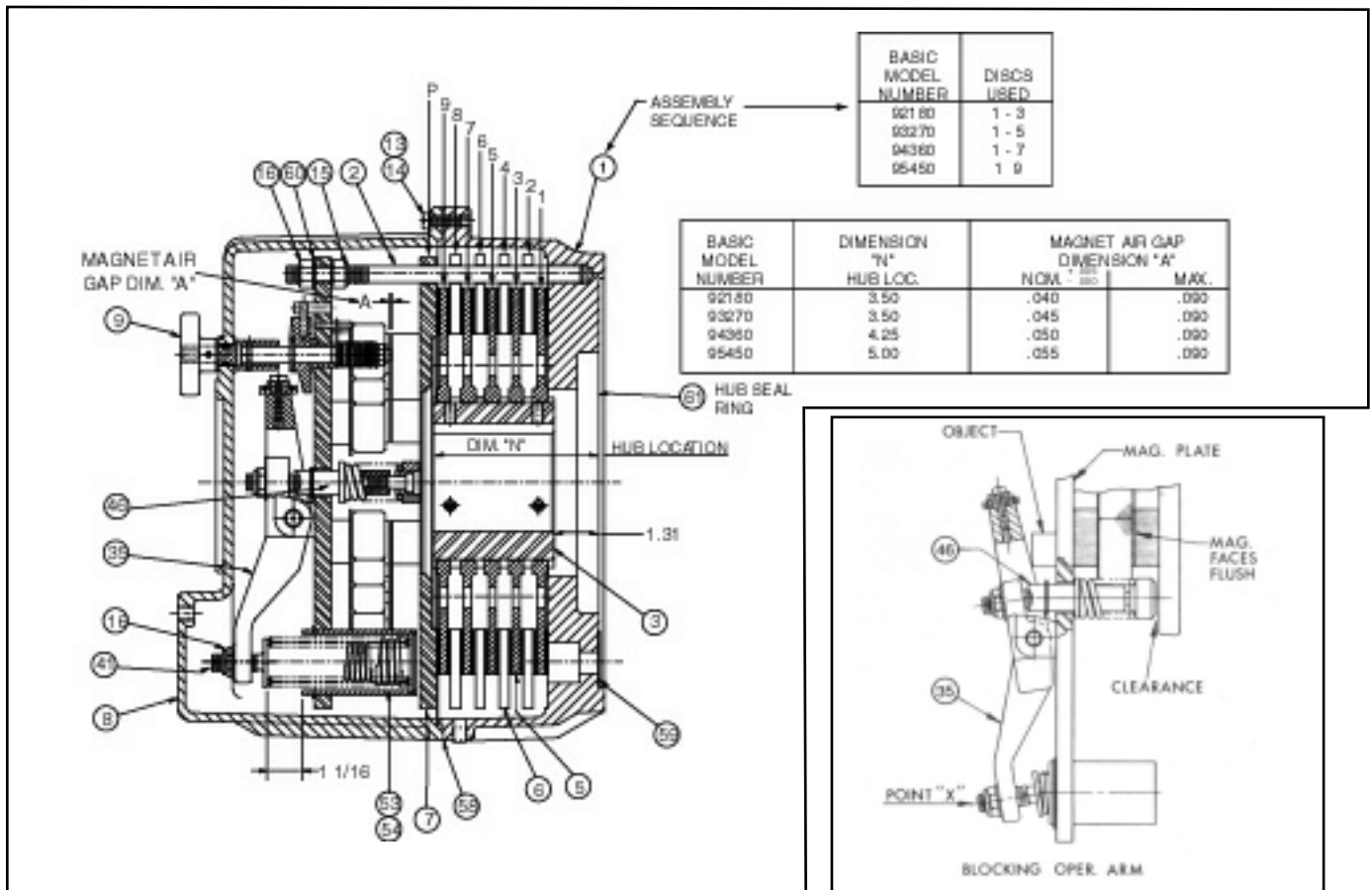

Figure 3.

Figure 4.

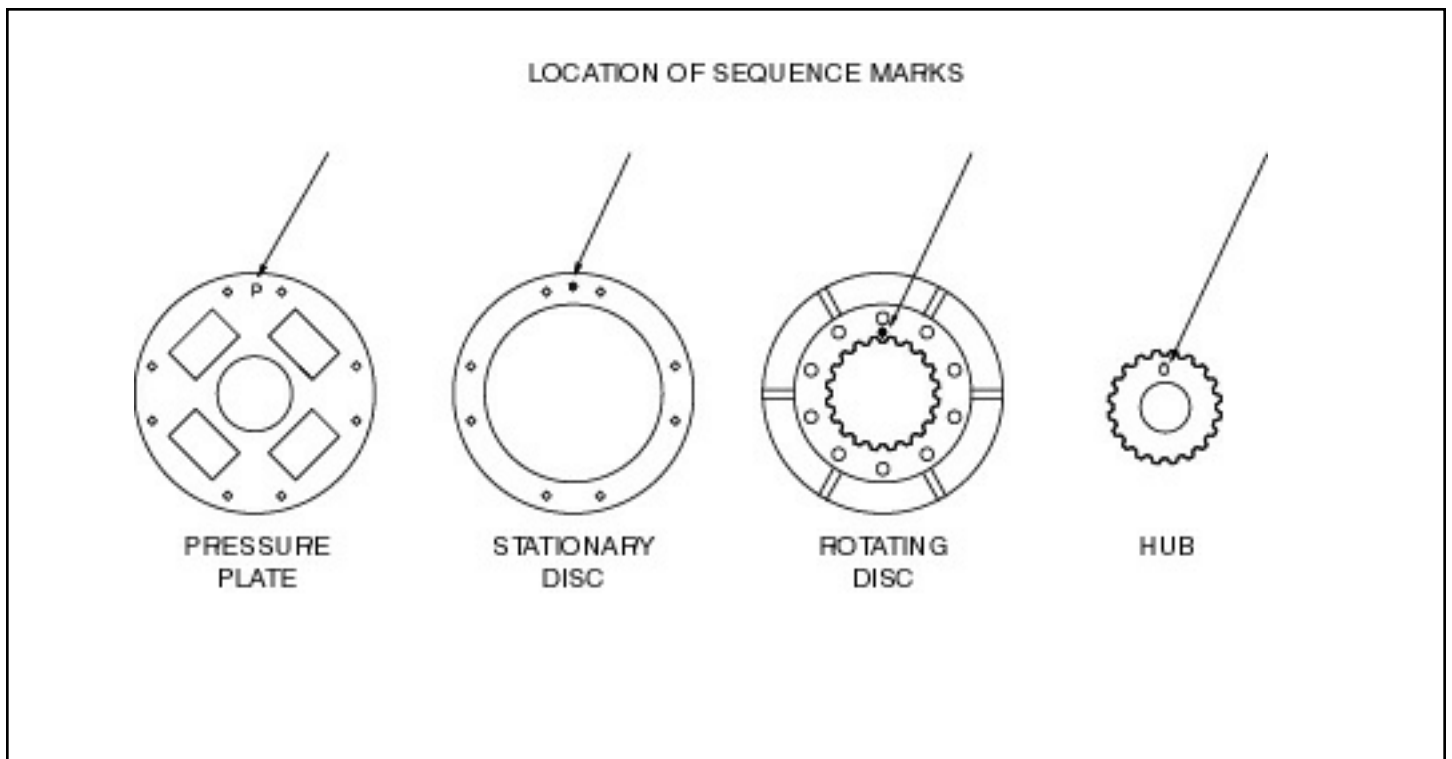

Figure 5.

WEAR ADJUSTMENT

(Refer to Figure 3)

NOTE: Do not remove operator assembly from brake, unless motor load is blocked. Removal of operator or blocking of operator arm, results in loss of all braking torque.

As the friction discs wear, the air gap increases. When the air gap reaches .090 maximum adjustment for wear is required.

1. Loosen jam nuts (15).
2. Tighten locknuts (16) until air gap at magnet is equal to the nominal air gap listed in Figure 3. Check all four magnets.
3. Tighten jam nuts evenly against magnet plate.
4. Adjust for magnet noise as outlined under INSTALLATION (Magnet Adjustment).

FRICTION DISC REPLACEMENT

(See Figures 3 & 5)

NOTE: Do not remove operator assembly from brake, unless motor load is blocked. Removal of operator or blocking of operator arm, results in loss of all braking torque.

When total wear on rotating friction disc (5) reaches $5/32$ " , the disc must be replaced. At this point the overall thickness of the disc will be approximately $1/4$ " .

1. Set the manual release. Remove cover screws (14), lockwashers (13), cover (8), locknuts (16), operator assembly (60), jam nuts (15) and pressure plate (7).
2. Remove rotating friction disc (5) and stationary disc (6). Replace worn friction disc. NOTE: To facilitate future disassembly, the new friction discs should be numbered so as to maintain the proper sequence of the discs.
3. Reassemble brake in reverse order. Be sure the stationary disc (6), rotating friction discs (5), and pressure plate (7) are in the correct sequence and position by checking the stamped markings on the parts. See Figure 5. Adjust magnet gap "A" as outlined under INSTALLATION (Magnet Adjustment).

MAGNET PLATE REPLACEMENT

(Refer to Figures 2, 3, 6 & 9.)

NOTE: Do not remove operator assembly from brake, unless motor load is blocked. Removal of operator or blocking of operator arm, results in loss of all braking torque.

Remove operator assembly (60) as outlined under FRICTION DISC REPLACEMENT.

DISASSEMBLY

Place the operator assembly so that the coil side is up. Insert a piece of threaded rod $1/4-20 \times$ " long through the torque spring holder (49) into the torque adjusting screw (41) and tighten firmly. With a matching nut, turn down on the torque spring bushing (52) until the spring pressure is removed from the snap ring (48). Remove the snap ring and slowly bring up the nut until the spring pressure is removed from the torque spring bushing. Remove the threaded rod and nut, plus the torque spring bushing, torque springs (53) and (54), and torque spring guide (55). Remove the manual release nut (31), washer (30), and return spring (29). Turn the operator assembly over so that the coil side is down. Loosen and remove the six hex socket head capscrews (26). Remove both pivot blocks (32) and (33), operator arm (35), and torque spring holder (51), release shaft assembly (56) and cam (27). Remove snap rings (47) and the shock absorber assemblies (46).

REASSEMBLY

Apply a thin coat of grease to the following areas: three bushings in the magnet plate (20) and (21), the spherical seat of both shock absorbers (46), and dowel pins (34) in both pivot blocks (32) and (33).

Place shaft (56) through cam (27) engaging pin (57) in cam slot. Insert shaft and cam through bushing (21) in magnet plate from side opposite the coils. The stop pin (28) in the cam should be as shown in Figure 6. Place return spring over shaft on side with coils on, hooking spring (29) over pin (22). Holding shaft and cam in position, rotate the tang end of return spring counter clockwise $1/4$ turn, engaging tang into slot on shaft end. Install washer (30) and nut (31). Tighten nut (31) to take up end play only. There should be spring pressure holding the stop pin the cam against the stop pin in the magnet plate.

Assemble remaining parts in reverse order of disassembly onto the new magnet plate. Place the assembled operator onto the brake and adjust magnet gap "A" as outlined under INSTALLATION (Magnet Adjustment). See OPERATOR ADJUSTMENT and MANUAL RELEASE ADJUSTMENT.

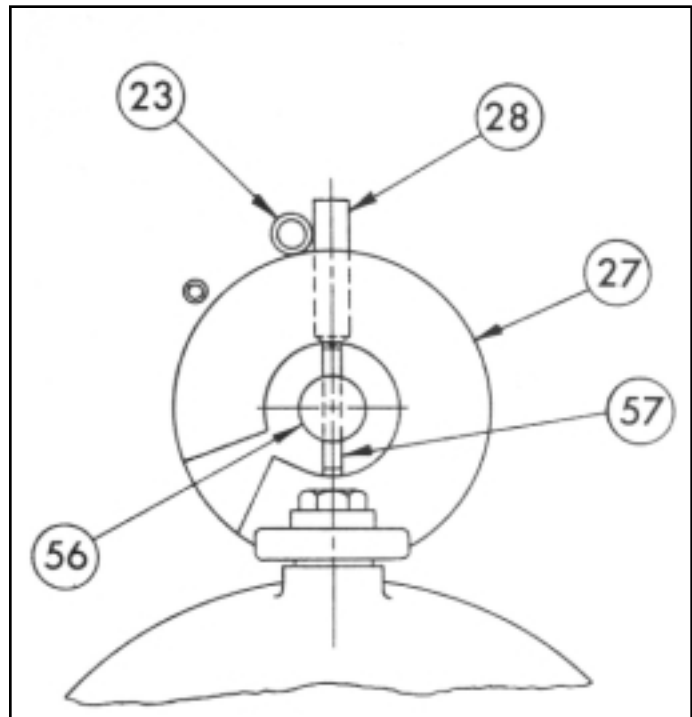

Figure 6.

OPERATOR ADJUSTMENT

(Refer to Figure 3.)

Check the position of the operator arm (35). The outside flat face of operator arm should be parallel with outside of magnet plate with brake de-energized. To do this, adjust as follows: Hold set screw (40) and loosen locknut (16) two full turns. (Typical two places, one each end of operator arm.) Backoff two set screws (40) two full turns. Block operator arm with an object so that it is parallel with the magnet plate. Finger tighten two set screws (40) until they make contact with shock absorbers (46). Hold set screws in position and tighten locknuts (16). After removing object, the operator arm should be parallel with magnet plate. Adjust torque spring length of $1 \frac{1}{6}$ " as outlined under TORQUE ADJUSTMENT.

MANUAL RELEASE ADJUSTMENT

(Refer to Figures 3, 7 & 9.)

AUTOMATIC RETURN: Check the manual release. Turn cam (27) clockwise until it stops. The brake should now be released. The cam and manual release shaft should return to its normal position when the brake is energized. If not, adjust as follows: Loosen the capscrew (36). With the brake energized and the cam turned clockwise the stop, turn eccentric bushing (37) until the bearing (38) makes contact with the cam surface. Hold bushing in this position and tighten capscrew. Check manual release for proper operation. **NOTE:** Due to the size of the discs, a slight drag is common (5-7 lb. ft.).

DEADMAN: Check the manual release. Turn cam (27) clockwise until it stops and hold it in this position. The brake should be released. The cam should return to its normal position when you let go of cam. If not, adjust as follows: Loosen the capscrew (36). With the brake de-energized and the release cam in its normal position, turn eccentric bushing (37) until the distance between the bearing (38) and face on cam (27) measures .21 inches. See Figure 7. Hold bushing in this position and tighten capscrew. Check manual release for proper operation. **NOTE:** Due to the size of the discs, a slight drag is common (5-7 lb. ft.).

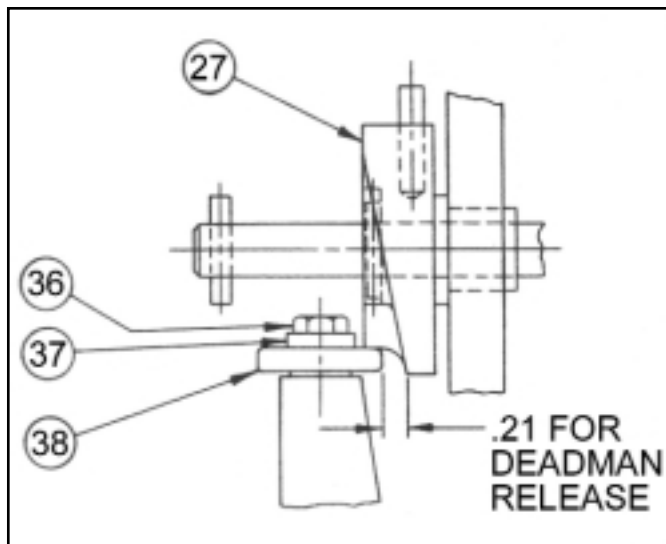

Figure 7.

MAGNET COIL ADJUSTMENT

(Refer to Figures 2, 3, 8 & 9.)

NOTE: Do not remove operator assembly from brake, unless motor load is blocked. Removal of operator or blocking of operator arm, results in loss of all braking torque.

Remove operator assembly as outlined under FRICTION DISC REPLACEMENT.

1. Coils (18) are held in place by epoxy cement or by bent over end magnet laminations. Force coil off magnet if held by epoxy and remove excess epoxy from the magnet surfaces, or bend up the end laminations and remove coil.
2. Replacement coils are held in place by bending of end laminations. (See Figure 8.) Insulating washers (19) are used above and below the coil on replacements. Order insulating washers when ordering a coil. When installing coils, it is very important to follow EXACTLY the sequence of the black and white leads as shown in the wiring diagram. Brake will not operate properly unless coils are in the correct position. (See Figure 2.)
3. Reassemble brake as outlined under INSTALLATION.

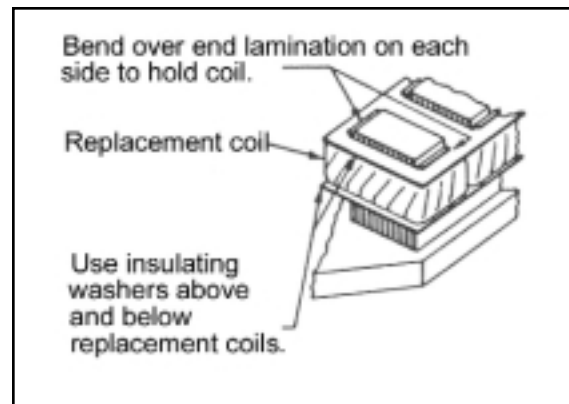

Figure 8. Fastening of Replacement Magnet Coils

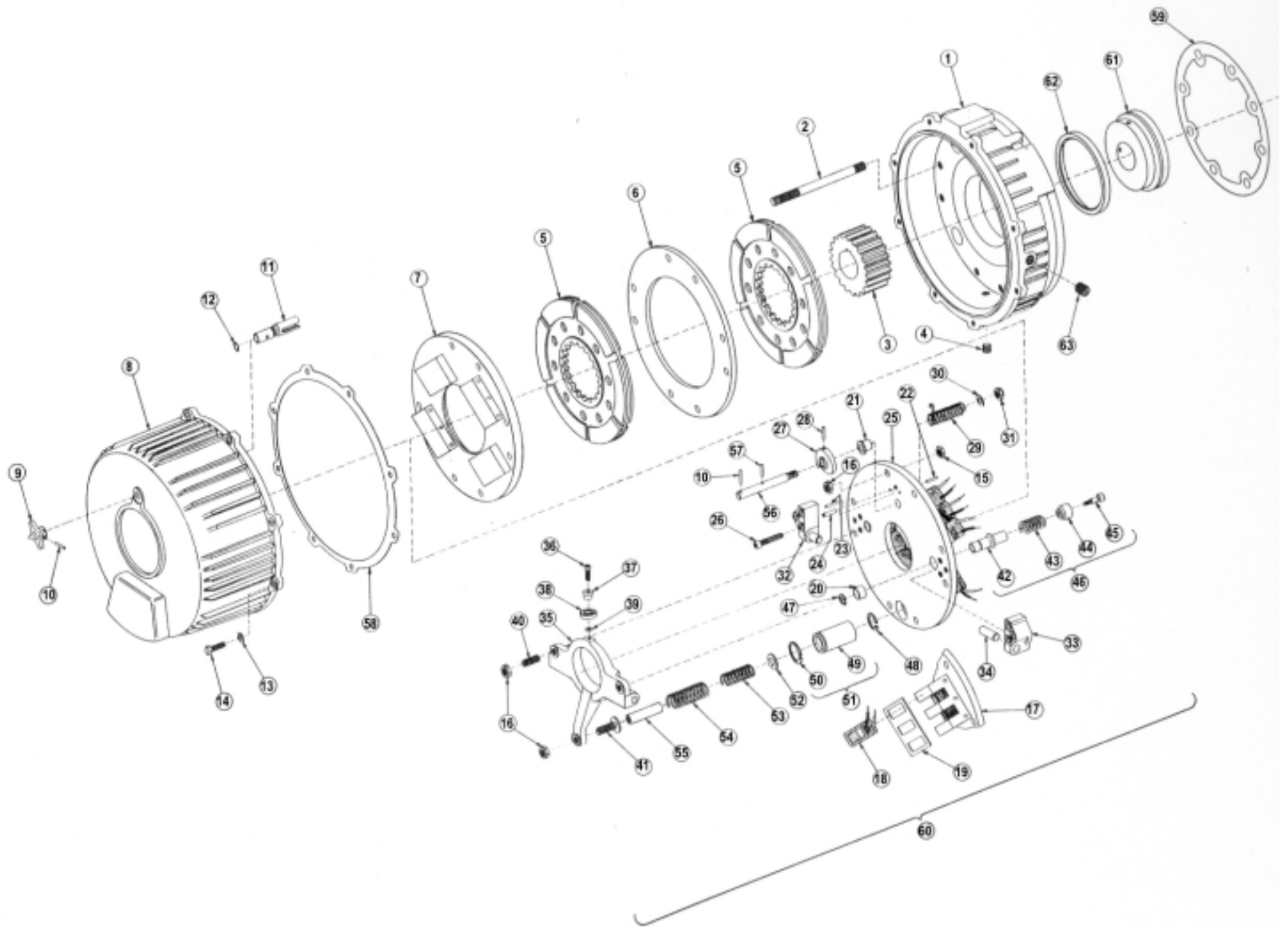

Figure 9.

Table 1. Parts List

REF. NO.	QTY.	DESCRIPTION	STD. HSG. 2-90000-30 SERIES PART NO.	ENCL. HSG. 4-90000-31 SERIES PART NO.	SEVERE DUTY HSG. 6-90000-32 SERIES PART NO.
1	1	Bracket 2 & 3 Disc Model	L090117-001	L090127-001	L090117-001
1	1	Bracket 4 & 5 Disc Model	L090118-001	L090128-001	L090118-001
2	8	Stud 2 Disc Model		H090092-001	
2	8	Stud 3 Disc Model		H090092-002	
2	8	Stud 4 Disc Model		H090092-003	
2	8	Stud 5 Disc Model		H090092-004	
3*	1	Hub Assembly 2 & 3 Disc Model		K090123	
3*	1	Hub Assembly 4 Disc Model		K090124	
3*	1	Hub Assembly 5 Disc Model		K090125	
4	1	Pipe Plug		W010002-002	
5	Note 1	Rotating Disc Assembly		K090122-001	
6	Note 2	Stationary Disc		K090107-001	
7	1	Pressure Plate Assembly		K090115-001	
8	1	Cover		L090119-001	
9	1	Release Knob		G090275-001	
10	2	Pin 3/16" x 1.0"		W005003-139	
11	1	Shaft Extension		H090111-001	
12	1	"O" Ring		W006001-003	
13	8	Lockwasher 3/8"		W004006-008	
14	8	Hex Head Capscrew		W001007-057	
15	8	Jam Nut 1/2-20		W003003-023	
16	11	Locknut 1/2-20		W003001-020	
17	1	Magnet Plate Assembly		L090103-001	
18**	12	Magnet Coil		H090099	
19	4	Insulating Washer		G080016-001	
20	2	Bushing		W013001-001	
21	1	Bushing		W013002-001	
22	1	Pin 1/8" x 1.0"		W005003-077	
23	1	Pin 3/16" x 1.0"		W005003-139	
24	1	Pin 5/16" x 1.0"		W005003-263	
25***	1	Mag. Assy. W/Coils-Auto Return Rel.-Standard		L090121	
25***	1	Mag. Assy. W/Coils-Deadman Release-Special		L090132	
26	6	Hex Socket Head Capscrew		W001013-113	
27	1	Cam – Auto Return Release – Standard		H090102-001	
27	1	Cam – Deadman Release – Special		H090101-001	
28	1	Pin 7/32" x 1.0"		W005003-232	
29	1	Return Spring		H090089-001	
30	1	Washer		W004004-009	
31	1	Nut 3/8-24		W003001-018	
32****	1	Pivot Block Assembly – L.H.		H090106-001	
33****	1	Pivot Block Assembly – R.H.		H090105-001	
34	2	Lok Dowel 1/2" D x 1.5"		W005007-058	
35	1	Operator Arm		K090126-001	
36	1	Hex Head Capscrew		W001008-003	
37	1	Bearing Sleeve		G090267-001	
38	1	Ball Bearing		W009001-013	
39	1	Washer 1/4"		W004003-022	
40	2	Hex Socket Head Set Screw		W002010-015	
41	1	Torque Adjusting Screw		G090264-001	
42	2	Pressure Rod		G090262-001	
43	2	Pressure Spring		G090259-001	
44	2	Seat		G090266-001	
45	2	Hex Soc. Hd. Shld. Screw		W001010-048	
46	2	Shock Absorber Assembly		H090103-001	
47	2	Snap Ring		W006006-003	
48	1	Snap Ring		W006009-001	
49	1	Torque Spring Holder		G090258-001	
50	1	Snap Ring		W006006-004	
51	1	Torque Spring Hldr. Assembly		H090104-001	
52	1	Torque Spring Bushing		G090263-001	
53	1	Torque Spring – Inner		G090261-001	
54	1	Torque Spring – Outer		G090260-001	
55	1	Torque Spring Guide		G090278-001	
56*****	1	Release Shaft Assembly – Models 92180 & 94360		G090277-001	
56*****	1	Release Shaft Assembly – Models 93270 & 95450		G090277-002	
57	1	Pin 1/8" x 7/8" Driv Lok		W005004-001	
58	1	Cover Gasket	-----	K090121-001	K090121-001
59	1	Mounting Face Gasket	-----		K090134-001
60	1	Operator Assembly 2 & 4 Disc (Standard Release)		L090120-001	
60	1	Operator Assembly 3 & 5 Disc (Standard Release)		L090120-002	
60	1	Operator Assembly 2 & 4 Disc (Deadman Release)		L090120-005	
60	1	Operator Assembly 3 & 5 Disc (Deadman Release)		L090120-006	
61*	1	Seal Ring	-----	H090117	-----
62	1	Seal	-----	W011001-013	-----
63	1	Pipe Plug		W010002-004	

* Specify Hub Bore and Keyway Size
 ** Specify Voltage and Frequency
 *** Specify Voltage and Frequency
 Item 25 includes Items 17 thru 24

**** Items 32 and 33 include Item 34
 ***** Item 56 includes Items 10 and 57

Note 1 Number of Rotating Disc is Shown as Second Digit of Model No.
 Example: 2-93270-30 Has 3 Discs.
 Note 2 Number of Stationary Discs is One Less Than the Number of Rotating Discs.

TROUBLE SHOOTING

A. IF BRAKE DOES NOT RELEASE:

1. Check brake visually for broken or damaged parts.
2. Check for broken leadwire or bad electrical connection.
3. Check for correct voltage. Line voltage must correspond to the voltage for which the brake coils are connected. If the line voltage is more than 10% below the voltage for which the brake coils are connected, the magnet will not pull in, causing the coils to burn out within minutes. If the line voltage is more than 10% above the voltage for which the brake coils are connected, the coils will overheat and burn out.
4. Check for burned-out coils (coils may be charred or burned).
5. Check for excessive magnet gap. (See WEAR ADJUSTMENT.)
6. Check for failure of power supply to brake.

B. IF BRAKE DOES NOT STOP:

1. Check brake visually for broken or damaged parts.
2. Make certain hub has not shifted position on the motor shaft and that all rotating discs are fully engaged on the hub.
3. Check that the manual release is in the normal position.

C. IF BRAKE CHATTERS OR HUMS:

1. See that magnet faces are clean. To remove dirt, insert a clean sheet of paper between magnet faces and energize brake. Move paper around between faces to dislodge dirt, then remove paper.
2. Check for low voltage. Magnet will not pull in, and coils will burn out if line voltage is beyond 10% below the voltage the brake coils are connected for.
3. See that magnet faces are parallel within tolerance (+.005 between the four corners of the magnet) Loud humming noise may be subsided. See INSTALLATION (Magnet Adjustment) for proper procedure.

D. IF MANUAL RELEASE DOES NOT WORK:

1. Check for broken or damaged parts.
2. Check to see if manual release is set properly. See MANUAL RELEASE ADJUSTMENT.

NOTE: Due to the size of the discs, a slight drag is common when the manual release is properly set (5-7 lb. ft.).

SERVICE RECORD

DATE	MAINTENANCE PERFORMED	COMPONENTS REQUIRED

