



80 Series 2 Post Standard Enclosure Brake Instructions

Read carefully before attempting to assemble, install, operate or maintain the product described. Protect yourself and others by observing all safety information. Failure to comply with instructions could result in personal injury and/or property damage! Retain instructions for future reference. When unpacking the brake, inspect it carefully for damage that may have occurred during transit.



Figure 1.

WARNING

Brake performance and features must be carefully matched to the requirements of the application.

Consideration must be given to torque requirements, especially where an overhauling condition exists, as well as thermal capacity, ambient temperature, atmospheric explosion hazards, type of enclosure and any other unusual conditions.

Improper selection and installation of a brake and/or lack of maintenance may cause brake failure which could result in damage to property and/or injury to personnel.

If injury to personnel could be caused by brake failure, additional means must be provided to insure safety of personnel.

Do not operate manual release or energize brake coil before installation, in order to preserve prealignment of rotating discs for ease of installation.

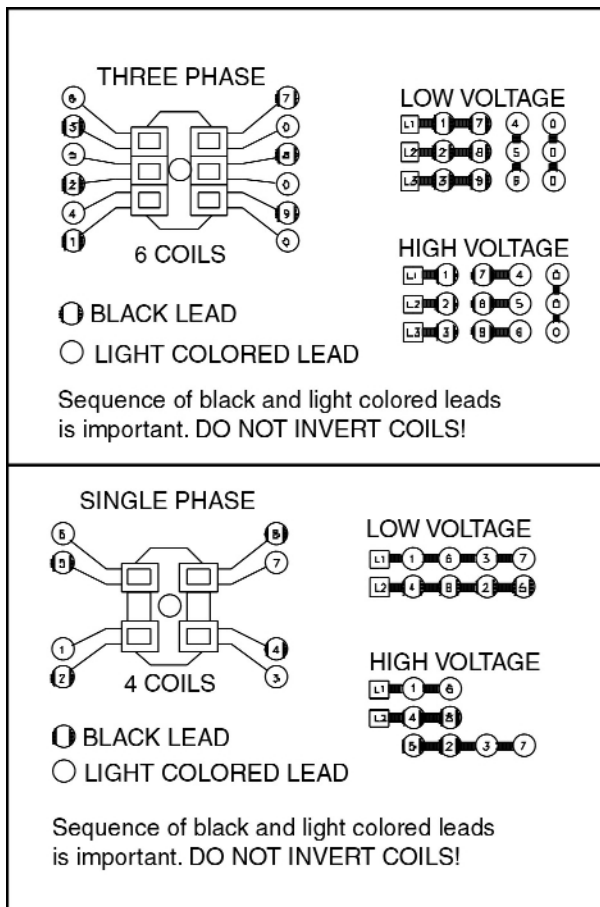

Figure 2. Wiring Diagram

DESCRIPTION

This brake is direct acting, electromagnetically released and spring set. It uses rotating and stationary disc contact to supply positive braking action. It retains quick release and setting capabilities at all times.

Simplicity of design has reduced maintenance to an absolute minimum. As with any electromechanical equipment, however, periodic inspection and adjustment will assure optimum performance. As the friction disc wears, the magnet gap will increase. The magnet gap should be checked periodically and adjusted when necessary.

SPECIFICATIONS

MOTOR FRAMES - 284TC, 286TC.

HOUSINGS - Cast iron and aluminum.

DUTY - Rated for continuous duty.

VOLTAGES - All standard NEMA voltages and frequencies available. Other voltages and frequencies are optional.

MOUNTING - Direct to NEMA "C" motor flanges. Adaptors for larger or smaller frames, foot mounting and vertical mounting are available.

SHAFTS - NEMA standard length motor shafts and thru shafts may be used on all models except units with Mark II Release (Cover modification required for thru shafts).

ORDERING INFORMATION

The following data should be furnished with your order for:

REPLACEMENT PARTS

Brake Model Number

Part Number from Tables

Part Description from Tables

(On hub order furnish bore dia. & keyway dimensions. On electrical parts specify voltage, phase & frequency.)

REPLACEMENT BRAKE

Model Number

Voltage, Phase & Frequency

Hub Bore & Keyway Dimensions

Mounting - Horizontal or Vertical. (If vertical, specify whether above or below motor. If brake includes foot mounting bracket or adaptor, specify.)

INSTALLATION

(See Figures 3 & 5, Tables 1 & 2)

1. Remove hub (21) from brake and position on motor shaft with key according to dimension "N". Stamped part number on hub should face away from motor. Tighten hub set screws with 12 lb. ft. torque.
2. Remove cover screws (16) and cover (17).
3. Place brake on motor, guiding discs on hub.
4. Bolt brake to motor "C" face with four 1/2 inch socket head cap screws. See Figure 5 for screw length thru bracket.
5. Connect coil leads per appropriate wiring diagram in Figure 2 and replace cover.

MANUAL RELEASE

(See Figure 3)

To operate release, rotate two rods (7) clockwise until stop screw (9) hits pin. Brake will remain in released position until rods are manually returned to original position, or until electrical power is restored which automatically returns the release rods to the set position.

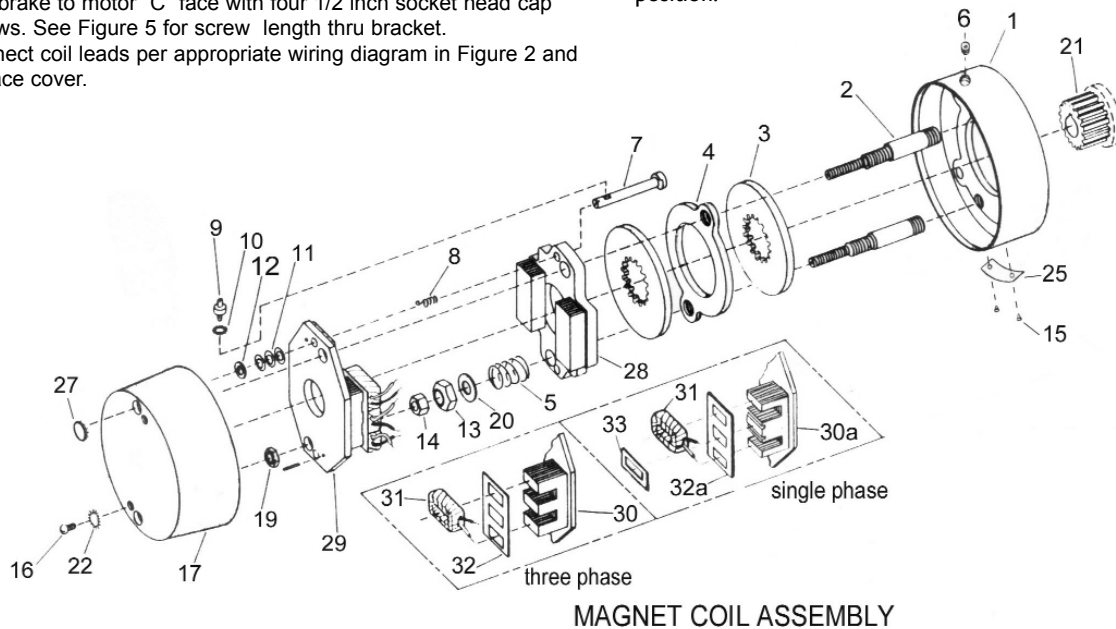

Figure 3. Exploded View of Brake

TORQUE ADJUSTMENT

(See Figures 3 & 5)

Brake is factory set for rated torque per spring length "H". To increase stopping time and lower torque, turn two locknuts (13) counterclockwise, increasing dimension "H". All two springs must be set to the same length. Do not decrease spring length "H" as this may cause coil to burn out.

WEAR ADJUSTMENT

(See Figures 3 & 5, Table 2)

Magnet gap "D" increases as friction discs wear. When gap approaches "D" max., adjust gap to "D" min. dimension by turning nuts (14 and 19). Magnet gap can vary from nominal $\pm .005$ " between corners. After setting gap, readjust torque spring length "H".

CAUTION: MAGNET GAP MUST NOT EXCEED "D" MAXIMUM.

FRICTION DISC REPLACEMENT

(See Figures 3 & 5, Table 2)

*When the rotating friction disc (3) wears down to a thickness of 7/32", replace disc.

1. Remove cover screws (16) and cover (17).
2. Unhook loop of torsion springs (8) from pins at rear of magnet plate (29). Remove release stop screws (9), washers (12) and shims (11).
3. Remove adjusting lock nuts (19), magnet assembly (29), adjusting nuts (14), torque nuts (13), washers (20), torque spring (5) and pressure plate (28).
4. Remove friction disc (3) and stationary disc (4). Replace worn friction discs.
5. Reassemble all parts in reverse order. Set spring length "H" and magnet gap "D". Assemble manual release. See following paragraph.

MANUAL RELEASE ASSEMBLY

(See Figure 3)

When assembling a standard manual release mechanism (Figure 3), add only enough shim washers (11) to obtain proper release action. Too many shim washers will prevent automatic reset when electrical power is applied. Too few washers will prevent the motor shaft from turning freely. Replace stop screws (9). Wind each torsion spring (8) approximately 1/4 turn and hook spring loop over pin.

MAGNET COIL REPLACEMENT

(See Figures 3 & 4)

Remove magnet assembly as outlined under FRICTION DISC REPLACEMENT.

Coils (31) are held in place with epoxy cement. Force coil off magnet mounting plate and remove excess epoxy from all surfaces.

Replacement coils should be held in place with new epoxy cement. The epoxy cement should be heat resistant and shock resistant. Place an insulating washer (32 or 32a) below the coils. Order insulating washers when ordering coils. An insulating washer can be cut to suit when replacing only one coil on a multiple coil assembly.

When installing coils, it is very important to follow EXACTLY the sequence of black and light colored leads as shown in wiring diagram (Figure 2). The brake will not operate properly unless coils are all in the correct position.

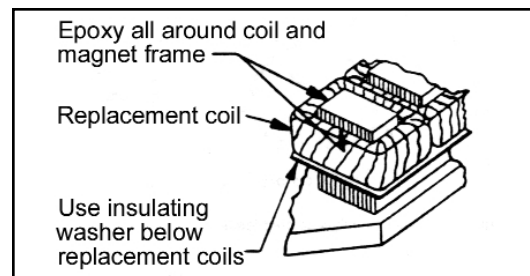

Figure 4. Fastening of Replacement Magnet Coils

Table I. Parts List

ITEM NO.	PCS. REQ'D	DESCRIPTION	PART NO.
1	1	Bracket – 1Disc	L080039-001
1	1	Bracket – 2 Disc	L080039-002
1	1	Bracket – 3 Disc	L080039-003
1	1	Bracket – 4 Disc	L080039-004
1	1	Bracket – 5 Disc	L080039-005
2	2	Stud – 1 Disc	G070213-001
2	2	Stud – 2 Disc	G070213-002
2	2	Stud – 3 Disc	G070213-003
2	2	Stud – 4 Disc	G070213-004
2	2	Stud – 5 Disc	G070213-005
3	(1)	Rotating Friction Disc	H080002-002
4	(2)	Stationary Disc	K080001-003
5	2	Torque Spring (25, 50, 75 Lb. Ft.)	G080001-001
5	2	Torque Spring (35, 70, 105, 125, 175 Lb. Ft.)	G080002-001
6	1	Cap Plug	G070001-002
7	2	Manual Release Rod	G070001-002
8	2	Manual Release Spring	G060010-001
9	2	Manual Release Stop Screw	G060029-001
10	2	Manual Release Lockwasher	W004007-007
11	As Req'd	Manual Release Shims	W004004-004
12	2	Washer	W004004-003
13	2	ESNA Nut	W003001-022
14	2	Hex Nut	W003003-023
15	2	Drive Screw	W001012-048
16	2	Cover Screw	W001002-103
17	1	Cover	K080287-001
18	1	Instruction Label (not shown)	H060058-002
19	2	ESNA Nut	W003001-020
20	2	Washer	W004004-001
21	1	Hub	*
22	2	Ext. Tooth Lockwasher	W004008-006
25	1	Nameplate	K060473-001
27	2	Button Plug	W008001-007
28	1	Pressure Plate Assembly	K080012-001
29	1	Magnet Assembly	*
30	1	Magnet Plate w/o Coils 3p	K080014-001
30a	1	Magnet Plate w/o Coils 1p	K080015-001
31	1	Magnet Coil	*
32	2	Insulating Washer 3p	G080016-001
32a	2	Insulating Washer 1p	G080148-001
33	2	Shading Coil, 1p only	G080022-001

(1) Number of rotating discs is shown as second digit of Model No.

Example: 6-82050-27

(2) Number of stationary discs is one less than the number of rotating discs.

* Part number will vary with voltage, frequency, bore size etc. Call for details.

Table 2. Standard Housing

MODEL NO.	TORQUE LB. FT.	WEIGHT LBS.	THERMAL CAPACITY HPS/MIN	INERTIA WK ² LB. FT. ²	DIMENSIONS						
					C	D		H	N	AC	X
						MAX	MIN				
6-81025-57	25	50	15	.084	6.00	.065	.040	1.28	1.75	1.72	1.00
6-81035-57	35	50	15	.084	6.00	.065	.040	1.28	1.75	1.72	1.00
6-82050-57	50	55	17	.158	6.62	.065	.040	1.28	2.25	2.34	1.50
6-82070-57	70	55	17	.158	6.62	.065	.040	1.28	2.25	2.34	1.50
6-83075-57	75	60	19	.233	7.25	.070	.040	1.28	2.75	2.97	2.00
6-83105-57	105	60	19	.233	7.25	.070	.040	1.28	2.75	2.97	2.00
6-84125-57	125	66	21	.307	7.87	.080	.050	1.37	3.25	3.59	2.50
6-85175-57	175	72	21	.384	8.50	.080	.050	1.28	3.87	4.22	3.12

